

## Electronic Damper Actuators Spring Return

### Easily Replaces:

- Belimo TF Series



### 20 lb.-in. Torque

- 24 Vac/dc, 2-position (Open/Closed) Control
- 120 Vac, 2-position (Open/Closed) Control
- 24 Vac/dc, Floating Control
- 24 Vac/dc, 2 to 10 Vdc/10 to 2 Vdc, (Modulating) Control



GQD Series Spring Return  
Direct Coupled Electronic Damper Actuator.

### Description

The OpenAir GQD Series direct-coupled, spring return electronic damper actuators are 24 Vac/dc and 120 Vac rated and available in 2-position, floating and 2 to 10 Vdc control.

### Features

- Bi-directional, fail-safe spring return
- Modulating actuators contain built-in feedback
- Pre-cabled
- Plenum rated
- Signal inversion capability on modulating type (2 to 10 Vdc/10 to 2 Vdc)
- Small footprint for installation flexibility
- UL, cUL, CE rated
- Quiet operation

### Options

- Available with optional built-in dual auxiliary switches fixed at 5° and 85°

### Applications

The small footprint and torque make this actuator ideal for small HVAC dampers, economizer units, or residential zone dampers requiring fail safe operation.

B-3

Damper Actuators



# GQD Series Specifications

**Operating Voltage** ..... 24 Vac/dc ±20%  
 120 Vac ±15%

**Frequency** ..... 50/60 Hz

**Power Consumption**

GQD121.1P (24 Vac/24 Vdc)  
 Running ..... 6.5 VA (4.5W)  
 Holding ..... 4 VA (2.5W)

GQD131.1P (24 Vac/24 Vdc)  
 Running ..... 4 VA (2.5W)  
 Holding ..... 3 VA (1.5W)

GQD151.1P (24 Vac/24 Vdc)  
 Running ..... 4.5 VA (3W)  
 Holding ..... 3.5 VA (2W)

GQD221.1U (120 Vac)  
 Running ..... 10 VA  
 Holding ..... 7 VA

**Function**

Torque ..... 20 lb.-in. (2 Nm)  
 Runtime for 90° ..... 30 sec.  
 Spring Return ..... 15 sec. nominal  
 Nominal Angle of Rotation ..... 90°

**Dual Auxiliary Switches**

Fixed at 5° and 85°

AC Rating ..... 24 to 250 Vac  
 AC 6A resistive  
 AC 2A General Purpose

DC Rating (Standard/Plenum Cable) ..... 12 to 30 Vdc  
 DC 2A

**Shaft Size** ..... 3/8 to 1/2-in. (8 to 13.4 mm) round/square ● ■

**Min. Shaft Length** ..... 3/4-in (20 mm)

**Conduit Connection** ..... (GQD221.1U only) 1/2" NPT

**Housing Enclosure** ..... NEMA 1

**Material** ..... Plenum rated rugged plastic

**Ambient Temperature**

Operating ..... -25 to 130°F (-32 to 55°C)  
 Storage and Transport ..... -40 to 158°F (-40 to 70°C)

**Ambient Humidity** ..... 95% RH, non-condensing

**Agency Approvals** ..... UL873, cUL, CE rated

**Pre-Cabled Connection** ..... AWG 18

**Cable Length** ..... 3 ft. (0.9m)

**Dimensions** ..... <4.72" H x <2.75" W x <2.5" D  
 (<120 mm H x <70 mm W x <63 mm D)

**Shipping Weight** ..... <1.5 lbs. (<.68 kg)

B-4

## GQD Series Product Ordering

Control Signal	Cabling	Standard	Dual Auxiliary Switches
2-position (Open/Closed), 24 Vac/dc	Plenum Cable	<b>GQD121.1P</b>	<b>GQD126.1P</b>
	Plenum Cable/Bulk	<b>GQD121.1P/B</b>	—
2-position (Open/Closed), 120 Vac	Standard Cable	<b>GQD221.1U</b>	<b>GQD226.1U</b>
	Standard Cable/Bulk	<b>GQD221.1U/B</b>	—
Floating, 24 Vac/dc	Plenum Cable	<b>GQD131.1P</b>	<b>GQD136.1P</b>
	Plenum Cable/Bulk	<b>GQD131.1P/B</b>	—
2 to 10 Vdc/10 to 2 Vdc, (Modulating), 24 Vac/dc	Plenum Cable	<b>GQD151.1P</b>	<b>GQD156.1P</b>
	Plenum Cable/Bulk	<b>GQD151.1P/B</b>	—

**Ordering Note** Bulk packages contain 10 actuators unless otherwise noted.

Damper Actuators

# Dimensions

## GQD Series Open Air Spring Return Electronic Damper Actuator

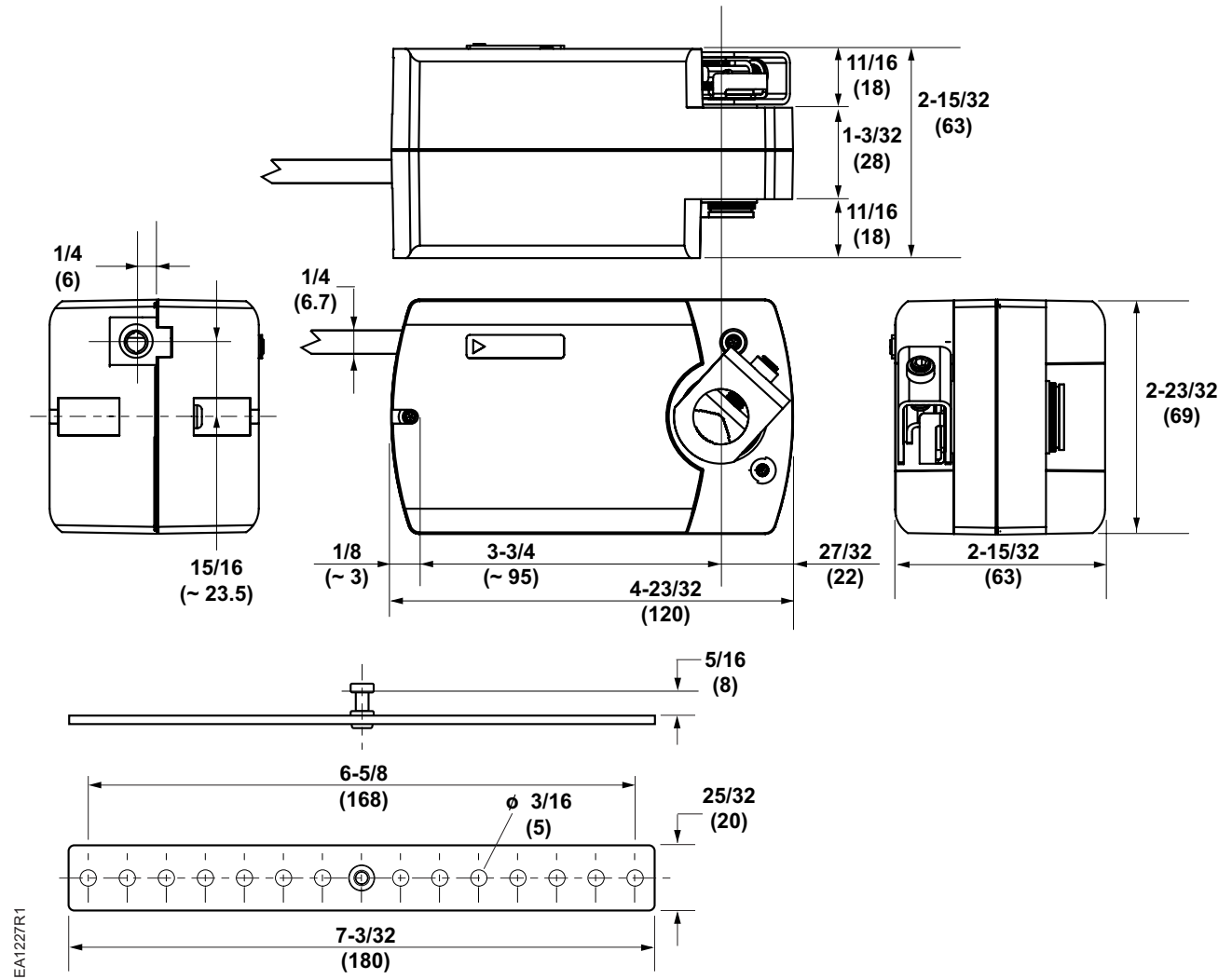

Dimensions shown in inches (mm).

